

# ASSEMBLY INSTRUCTIONS

## TODD DOUBLE and TRIPLE STEPS

TOOLS REQUIRED adjustable wrench, phillips head screwdriver

1. Place the TODD Step on side.  
The selected (left or right) side chosen for handrail UP.

2. Align the mounting holes in the handrail with the mounting holes in the step unit.

3. Place a washer on each of the 4 phillips head bolts

4. With handrail and step set holes aligned, place 1 short bolt in each of the lower aligned holes finger tighten a washer and nut on each bolt from the inside the step set unit.

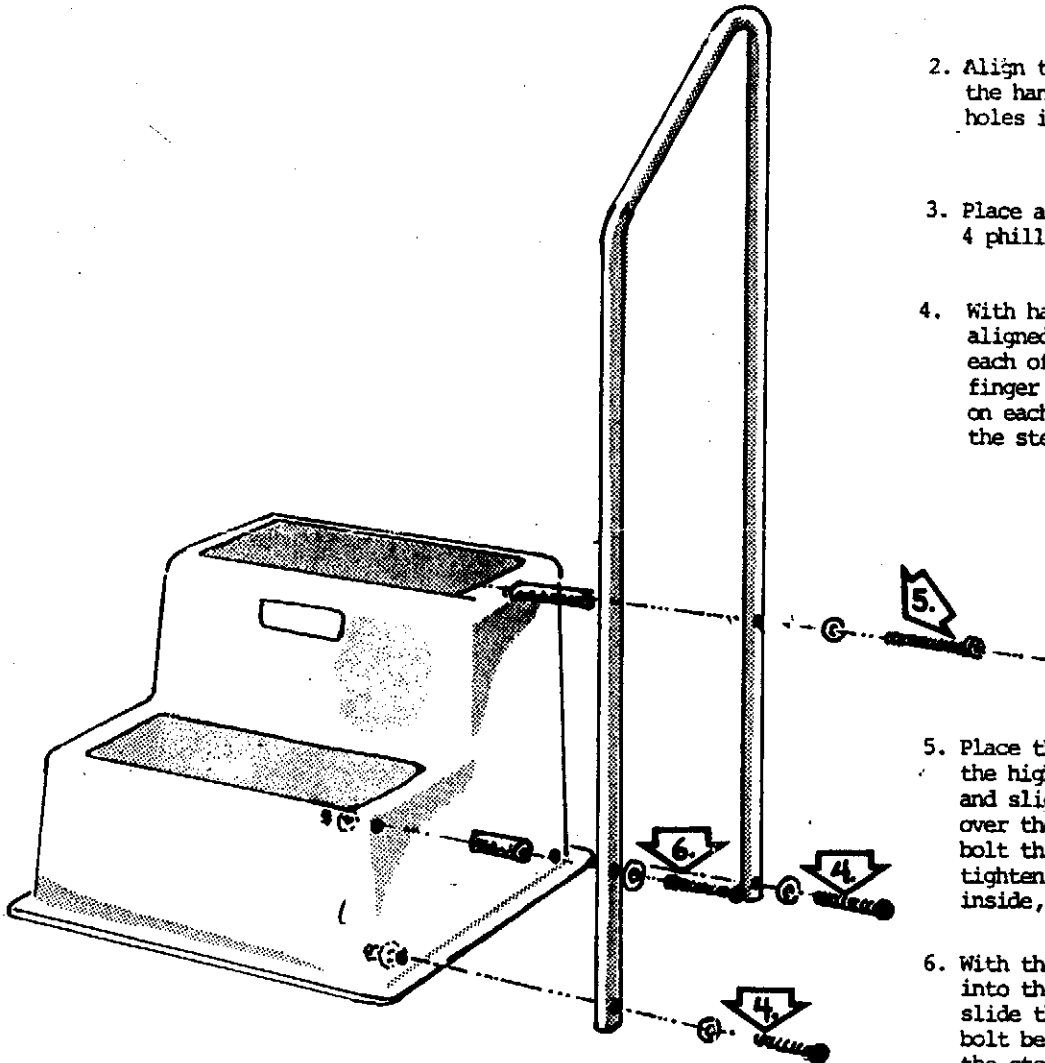

5. Place the longest bolt through the highest hole on the hand rail and slide the longest spacer over the bolt before inserting the bolt through step wall hole. Finger tighten 1 washer and nut from the inside, as above.

6. With the remaining bolt, place it into the remaining rail hole. slide the short spacer onto the bolt before inserting it through the step set wall. Place a washer and nut. Finger tighten

7. All bolts can be permanently secured with driver and wrench.



enterprises, inc.  
**todd**

The Poly Products People  
530 Wellington Avenue, Cranston, Rhode Island 02910  
Tel. (401) 467-2750/FAX (401) 467-2650